

Serie Valves

Valvole Elettropneumatiche

Solenoid Valve
Elektropneumatische Ventile
Distributeurs Électropneumatiques
Válvulas Electroneumáticas
Válvulas Eletro-pneumáticas



Serie 01V - X1V

Pag. 17.6 - 17.16

Valvole Asservite

Assisted Valve
Ventile Vorgesteuert
Distributeurs à Commande Assistée
Válvula Asistida
Válvula Piloto Externo



Serie 01V

Pag. 17.17 - 17.29

Valvole Pneumatiche

Pneumatic Valve
Pneumatische Ventile
Distributeurs Pneumatiques
Válvulas Neumáticas
Válvulas Pneumáticas



Serie 01V

Pag. 17.30 - 17.36

Valvole ad Azionamento Manuale

Manual Valve
Manuell Betätigte Ventile
Distributeurs à Commandes Manuel
Válvulas de Accionamiento Manual
Válvulas de Acionamento Manual



Serie 01V - X1V

Pag. 17.37 - 17.47

Valvole ad azionamento meccanico

Mechanically actuated valve
Mechanisch betätigte ventile
Distributeurs à commandes mécaniques
Válvulas de accionamiento mecánico
Válvula de accionamento mecánico



Serie 01V

Pag. 17.48 - 17.51

Basi Multiple

Multiple Bases
Mehrfach Grundplatten
Embases Multiples
Base Múltiple
Bases Múltiplas

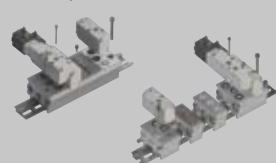

Serie 01V

Pag. 17.52 - 17.56

Micro Valvole

Micro Valves
Mikroventile
Microdistributeurs
Microválvulas
Micro-Válvulas



Serie 02V

Pag. 17.58 - 17.60

Valvole 16 mm

16 mm Valves
Ventile 16 mm
Distributeurs 16 mm
Válvulas 16 mm
Válvulas 16 mm



Serie 03V

Pag. 17.62 - 17.66

Valvole a Pannello, Pulsanti e Selettori

Panel Valve, Push Buttons and Selectors
Schalttafelventile, Taster und Schalter
Distributeurs pour commandes en panneau et boutons
Válvulas de Panel, Pulsadores, Selectores
Válvulas para Pannel, Pulsantes e Seletoras



Serie 04V

Pag. 17.68 - 17.70

Valvole VDMA 18 mm - Basi per Valvole VDMA 18 mm

18 mm VDMA Valve - 18 mm VDMA Bases
Ventile 18 mm VDMA - 18 mm VDMA Mehrfach Grundplatten
Distributeurs 18 mm VDMA - Embases multiples pour
Distributeurs 18 mm VDMA
Válvulas VDMA 18 mm - Base para Válvula VDMA 18 mm
Válvulas VDMA 18 mm - Bases Para Válvulas Vdma 18 mm



Serie 05V

Pag. 17.72 - 17.82

Valvole a Pedale

Pedal Valve
Valvole a Pedale
Distributeurs à Pédale
Válvulas a Pedal
Válvulas Pedal

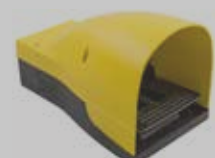

Serie 06V

Pag. 17.84 - 17.85

Elettropiloti

Solenoid Valve
Magnetventile
Electro Distributeurs
Electropilotos
Válvulas Solenóide



Serie 07V

Pag. 17.87 - 17.89

Elettropiloti Miniaturizzati 10 mm e 15 mm

Miniature Solenoid Valve 10 mm and 15 mm
Miniatur Ventile 10 mm und 15 mm
Distributeurs Miniature au pluriel 10 mm et 15 mm
Electropiloto Miniaturizado 10 mm y 15 mm
Eletropilotos Miniaturizados 10 mm e 15mm



Serie 07V

Pag. 17.90 - 17.96

Valvole NAMUR

NAMUR Valve
NAMUR Ventile
Distributeurs NAMUR
Válvulas NAMUR
Válvulas NAMUR



Serie 08V

Pag. 17.98 - 17.106

Valvola a Leva Manuale

Rotary Hand Lever Valve
Handhebeventil
Distributeur a Commande Manuelle
Válvula de Leva Manual
Válvula de Alavanca Manual



Serie 12V

Pag. 17.108 - 17.109

Valvola Elettropneumatica Modulare

Modula Solenoid Valve
Modulare Druckluft-elektromagnet-ventile
Ilots de Distribution Pneumatique
Válvulas Electroneumáticas Modulares
Válvulas Eletropneumáticas Modulares



Serie 15V

Pag. 17.111 - 17.144

Solenoidi e Connettori

Solenoid and Connectors
Magnetspulen und Stecker
Bobines et Connecteurs
Bobinas y Conectores
Solenóides e Conectores



Pag. 17.24 - 17.29 / 17.75

VALVOLE ELETTROPNEUMATICHE, PNEUMATICHE E MANUALI

MANUAL, PNEUMATIC AND SOLENOID PILOT VALVES

MANUELLE, PNEUMATISCHE & ELEKTROPNEUMATISCHE VENTILE

DISTRIBUTEURS ÉLECTROPNEUMATIQUES, PNEUMATIQUES & MÉCANIQUES

VÁLVULAS ELECTRONEUMÁTICAS, NEUMÁTICAS Y MANUALES

VÁLVULAS ELETRO-PNEUMÁTICAS, PNEUMÁTICAS E MANUAIS



Serie Valves

Serie 05V

VALVOLE 18 MM VDMA

VDMA 18 MM VALVE

VENTILE 18 MM VDMA

DISTRIBUTEURS 18 MM VDMA

VÁLVULAS 18 MM VDMA

VÁLVULA DE 18 MM VDMA



VALVOLE VDMA 18 MM AD AZIONAMENTO ELETTROPNEUMATICO

SOLENOID PILOT VALVE 18 MM VDMA
 ELEKTROPNEUMATISCHE VENTILE 18 MM VDMA
 DISTRIBUTEURS ÉLECTROPNEUMATIQUES 18 MM VDMA
 VÁLVULAS VDMA 18 MM DE ACCIONAMIENTO ELECTRONEUMÁTICO
 VÁLVULA VDMA DE 18 MM DE ACIONAMENTO ELETRO-PNEUMÁTICO



CARATTERISTICHE TECNICHE

TECHNICAL CHARACTERISTICS
 TECHNISCHE ANGABEN
 CARACTÉRISTIQUES TECHNIQUES
 CARACTERÍSTICAS TÉCNICAS
 CARACTERÍSTICAS TÉCNICAS



1907/2006
 REACH ✓

2011/65/CE
 RoHS ✓

PED
 2014/68/UE

ISO 15407-1
 VDMA 24563 SIZE 02 (18 mm)

	PORTATA a 6 BAR con Δp 1 bar 6 bar FLOW RATE with Δp 1 bar DURCHFLOßWERT BEI 6 bar mit Δp 1 bar DÉBIT DE REFERENCE à 6 bar avec Δp 1 bar CAUDAL a 6 BAR con Δp 1 bar VAZÃO a 6 BAR com Δp 1 bar		550 NI/min
	PRESSIONE DI FUNZIONAMENTO OPERATING PRESSURE BETRIEBSDRUCK PRESSION DE SERVICE PRESIÓN DE EJERCICIO PRESSÃO DE OPERAÇÃO	Monostable	2.5 ÷ 10 bar
		Bistable	1 ÷ 10 bar
	TEMPERATURA TEMPERATURE BETRIEBSTEMPERATUR TEMPÉRATURE DE TRAVAIL TEMPERATURA TEMPERATURA	min	-10 °C
		max	+60 °C
	TENSIONE SOLENOIDE SOLENOID VOLTAGE SPANNUNG DER MAGNETSPULEN TENSION DE LA BOBINE TENSION SOLENOIDE TENSÃO DA SOLENOIDE		24V DC ÷ 24V AC
	POTENZA MINIMA MINIMUM POWER MIN. LEISTUNG PUISSANCE MIN. POTÊNCIA MÍNIMA POTÊNCIA MÍNIMA		2W - 3VA
	COMANDO MANUALE MANUAL CONTROL MANUELLE BETÄTIGUNG COMMANDE MANUELLE COMANDO MANUAL ACIONAMIENTO MANUAL		MONOSTABILE MONOSTABLE MONOSTABIL MONOSTABLE MONOESTABLE MONOESTÁVEL
	TEMPI DI RISPOSTA RESPONSE TIME SCHALTZEITEN TEMPS DE RÉPONSE TIEMPO DE RESPUESTA TEMPOS DE RESPOSTA	Monostable	TRA = 13ms
			TRR = 26ms
			TRA=TRR = 24ms
		Bistable	TRA=TRR = 24ms

TRA = Tempo di risposta bobina eccitata
 Response time with energised coil
 Schaltzeit einer bestromten Spule
 Temps de réponse de la bobine sous tension
 Tiempo de respuesta bobina excitada
 Tempo de resposta com bobina acionada

TRR = Tempo di risposta bobina diseccitata
 Response time with deenergised coil
 Schaltzeit einer stromlosen Spule
 Temps de réponse bobine hors tension
 Tiempo de respuesta bobina desexcitada
 Tempos de resposta com bobina desacionada

Materiali e Componenti

IT

- 1 Corpo in alluminio anodizzato
- 2 Spola in alluminio nichelato
- 3 Guarnizioni in NBR

Component Parts and Materials

GB

- 1 Anodised aluminium body
- 2 Nickel-plated spool
- 3 NBR seals

Komponenten und Materialien

DE

- 1 Aluminiumgehäuse Eloxiert
- 2 Schieber aus Aluminium Vernickelt
- 3 Dichtungen aus NBR

Matériaux et Composants

FR

- 1 Corps en aluminium anodisé
- 2 Tiroir en aluminium nickelé
- 3 Joints en NBR

Materiales y Componentes

ES

- 1 Cuerpo en Aluminio Anodizado
- 2 Corredera en Aluminio Niquelado
- 3 Juntas en NBR

Materiais e Componentes

PT

- 1 Corpo em Alumínio Anodizado
- 2 Carretei Alumínio Niquelado
- 3 Vedação em NBR



Tabella dei codici di ordinazione

Ordering codes

Bestellschlüssel

Code de commande

Tabla de codificación para pedidos

Tabela de codificação para compra

SERIE	Azionamento Actuation Betätigung Actionnement Accionamiento Acionamento	Riazionamento Reactuation Rückstellung Rappel Reaccionamiento Retorno	Vie Ways Wege Voies Vias Vias	Funzione Function Funktion Fonction Función Funções	Misura Size Größe Dimension Medida Tamanho
-------	--	--	--	--	---

0 5 V

S

0

7

CC

0 0

- S = Solenoide**
Solenoid
Magnetspule
Bobine
Solenóide
Solenóide
- 0 = Monostabile con ritorno a molla**
Monostable spring return
Monostabil mit Federrückstellung
Monostable à rappel par ressort
Monoestable con retorno muelle
Monoestável com retorno por mola
- 1 = Bistabile**
Bistable
Bistabil
Bistable
Biestable
Biestável

5 = 5/2

7 = 5/3

CC = Centri chiusi
Normally closed
Mittelstellung geschlossen
Centre fermé
Centros cerrados
Centro fechado

OC = Centri aperti
Normally exhausted
Mittelstellung offen
Centre ouvert
Centros abiertos
Centro-aberto negativo

00 = Funzione non contemplata
Function not provided
Funktion steht nicht zur Verfügung
Fonction non disponible
Función no contemplada
Função não contemplada

00 = 24V DC

01 = 24V AC

5/2 Vie - Ways - Wege - Voies - Vias - Vias

MONOSTABILE CON RITORNO A MOLLA

MONOSTABLE SPRING RETURN

MONOSTABIL MIT FEDERRÜCKSTELLUNG

MONOSTABLE À RAPPEL PAR RESSORT

MONOESTABLE CON RETORNO POR MUELLE

MONOESTÁVEL COM RETORNO POR MOLA

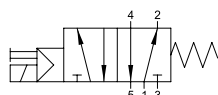

Codice Code Nummer Code Código Código	Vie Ways Wege Voies Vias Vias	Solenóide Solenoid Magnetspule Bobine Solenóide Solenóide	Pack.
05V S0 5 00 00	5/2	24V DC	1
05V S0 5 00 01	5/2	24V 50/60Hz	1

5/2 Vie - Ways - Wege - Voies - Vias - Vias

BISTABILE

TWO STABLE POSITIONS

BISTABIL

BISTABLE

BIESTABLE

BIESTÁVEL



Codice Code Nummer Code Código Código	Vie Ways Wege Voies Vias Vias	Solenóide Solenoid Magnetspule Bobine Solenóide Solenóide	Pack.
05V S1 5 00 00	5/2	24V DC	1
05V S1 5 00 01	5/2	24V 50/60Hz	1

5/3 Vie - Ways - Wege - Voies - Vías - Vias

MONOSTABILE CON RITORNO A MOLLA

MONOSTABLE SPRING RETURN

MONOSTABIL MIT FEDERRÜCKSTELLUNG

MONOSTABLE À RAPPEL PAR RESSORT

MONOESTABLE CON RETORNO POR MUELLE

MONOESTÁVEL COM RETORNO POR MOLA

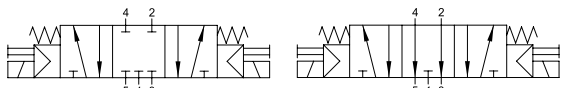

CC

OC

Codice Code Nummer Code Código Código	Vie Ways Wege Voies Vías Vias	Funzione Function Funktion Fonction Función Funções	Solenoide Solenoid Magnetspule Bobine Solenóide Solenóide	Pack.
05V S0 7 CC 00	5/3	CC	24V DC	1
05V S0 7 OC 00	5/3	OC	24V DC	1
05V S0 7 CC 01	5/3	CC	24V 50/60Hz	1
05V S0 7 OC 01	5/3	OC	24V 50/60Hz	1



05V S0 5 00 00 05V S0 5 00 01

05V S0 7 CC 00 05V S0 7 OC 00 05V S0 7 CC 01 05V S0 7 OC 01

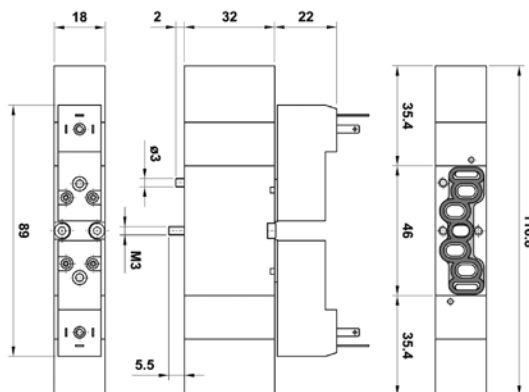
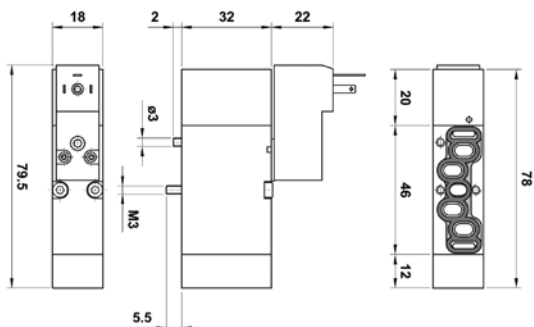

05V S1 5 00 00 05V S1 5 00 01

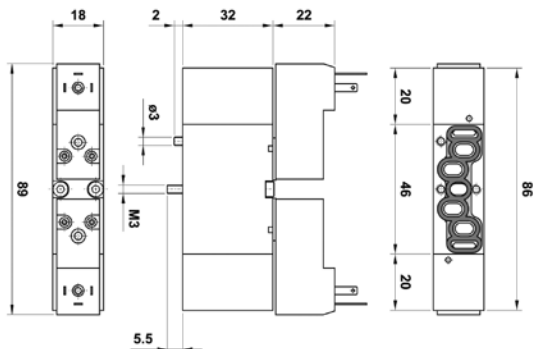

Connettori 15 mm

Connectors
Stecker
Connecteurs
Conectores
Conectores



Codice Code Nummer Code Código Código	Colore Color Farbe Couleur Color Cor	Caratteristiche Characteristics Eigenschaften Caractéristiques Características Características	Pack.
CON 11 000 01	■	2 POLI - Pins - Pins - Broches - Pins - Pinos	1
CON 12 024 00	□	LED + VDR 0 - 24V	1

■ NERO BLACK SCHWARZ NOIR NEGRO PRETO	□ TRASPARENTE TRANSPARENT TRANSPARENT TRANSPARENT TRANSPARENT TRANSPARENT
--	--

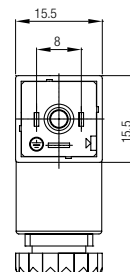

VDR: Dotati di Varistore come dispositivo di protezione delle sovratensioni.
Fitted with varistors as surge protection device.
Ausgestattet mit Varistor als ÜberSpannungsschutz.
Equipé avec varistance de protection contre les surtensions.
Dotado de Varistor como dispositivo de protección de sobretensiones.
Dotados de Varistor como dispositivo de proteção de sobretenção.

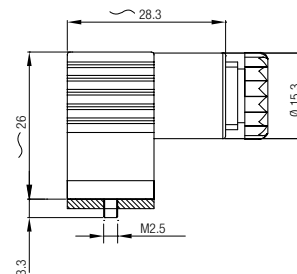

Schema elettrico

Wiring

Elektroschema

Schéma électrique

Esquema eléctrico

Esquema elétrico

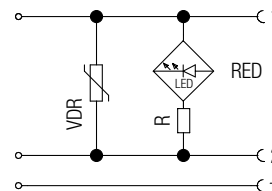
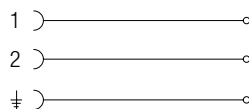

CON11 000 01

CON12 024 00

GRADO DI PROTEZIONE
 DEGREE OF PROTECTION
 SCHUTZART
 DEGRÉ DE PROTECTION
 GRADO DE PROTECCIÓN
 GRAU DE PROTEÇÃO

IP67 IEC 60529

DIAMETRO CAVO
 CABLE DIAMETER
 KABELDURCHMESSER
 DIAMÈTRE DU CÂBLE
 DIÁMETRO DEL CABLE
 DIÂMETRO DO CABO

4 ÷ 6 mm

TERMINALI
 TERMINALS
 VERBINDUNG
 CONNEXION
 TERMINALES
 TERMINAIS

DIN 4365 C

VALVOLE VDMA 18 MM AD AZIONAMENTO PNEUMATICO

PNEUMATIC VALVE 18 MM VDMA
 PNEUMATISCHE VENTILE 18 MM VDMA
 DISTRIBUTEURS PNEUMATIQUES 18 MM VDMA
 VÁLVULAS VDMA 18 MM DE ACCIONAMIENTO NEUMÁTICO
 VÁLVULA VDMA DE 18 MM DE ACIONAMENTO PNEUMÁTICO



CARATTERISTICHE TECNICHE

TECHNICAL CHARACTERISTICS
 TECHNISCHE ANGABEN
 CARACTÉRISTIQUES TECHNIQUES
 CARACTERÍSTICAS TÉCNICAS
 CARACTERÍSTICAS TÉCNICAS



Norma di Riferimento

Reference standard

Entspricht der Norm

Norme de référence

Normativa de referencia

Norma de referência



ISO 15407-1

VDMA 24563 SIZE 02 (18 mm)

	PORTATA a 6 BAR con Δp 1 bar 6 bar FLOW RATE with Δp 1 bar DURCHFLUSSWERT BEI 6 bar mit Δp 1 bar DÉBIT DE RÉFÉRENCE à 6 bar avec Δp 1 bar CAUDAL a 6 BAR con Δp 1 bar VAZÃO a 6 BAR com Δp 1 bar		550 Nl/min
	PRESSIONE DI AZIONAMENTO PRESSURE DRIVE STEUERDRUCK PRESSION DE COMMANDE PRESIÓN DE ACCIONAMIENTO PRESSÃO DE ACIONAMENTO		0 ÷ 10 bar
	PRESSIONE DI FUNZIONAMENTO OPERATING PRESSURE BETRIEBSDRUCK PRESSION DE SERVICE PRESIÓN DE EJERCICIO PRESSÃO DE OPERAÇÃO	Monostable	2 ÷ 10 bar
		Bistable	1 ÷ 10 bar
	TEMPERATURA TEMPERATURE BETRIEBSTEMPERATUR TEMPÉRATURE DE TRAVAIL TEMPERATURA TEMPERATURA	min	-10 °C
		max	+60 °C
	TEMPI DI RISPOSTA RESPONSE TIM SCHALTZEITEN TEMPS DE RÉPONSE TIEMPO DE RESPUESTA TEMPOS DE RESPOSTA	Monostable	TRA = 12 ms
			TRR = 24 ms
		Bistable	TRA=TRR = 21 ms

TRA = Tempo di risposta bobina eccitata

Response time with energised coil
 Schaltzeit einer bestromten Spule
 Temps de réponse de la bobine sous tension
 Tiempo de respuesta bobina excitada
 Tempo de resposta com bobina acionada

TRR = Tempo di risposta bobina diseccitata

Response time with deenergised coil
 Schaltzeit einer stromlosen Spule
 Temps de réponse bobine hors tension
 Tiempo de respuesta bobina desexcitada
 Tempos de resposta com bobina desacionada

Materiali e Componenti

IT

- 1 Corpo in alluminio anodizzato
- 2 Spola in alluminio nichelato
- 3 Guarnizioni in NBR

Component Parts and Materials

GB

- 1 Anodised aluminium body
- 2 Nickel-plated spool
- 3 NBR seals

Komponenten und Materialien

DE

- 1 Aluminiumgehäuse Eloxiert
- 2 Schieber aus Aluminium Vernickelt
- 3 Dichtungen aus NBR

Matériaux et Composants

FR

- 1 Corps en aluminium anodisé
- 2 Tiroir en aluminium nickelé
- 3 Joints en NBR

Materiales y Componentes

ES

- 1 Cuerpo en Aluminio Anodizado
- 2 Carretera en Aluminio Niquelado
- 3 Juntas en NBR

Materiais e Componentes

PT

- 1 Corpo em Alumínio Anodizado
- 2 Carreter Aluminio Niquelado
- 3 Vedação em NBR



Tabella dei codici di ordinazione

Ordering codes

Bestellschlüssel

Code de commande

Tabla de codificación para pedidos

Tabela de codificação para compra

SERIE	Azionamento Actuation Betätigung Actionnement Accionamiento Acionamento	Riazionamento Reactuation Rückstellung Rappel Reaccionamiento Retorno	Vie Wege Voies Vias Vias	Funzione Funktion Funktion Fonction Función Funções	Misura Size Größe Dimension Medida Tamanho
-------	--	--	--------------------------------------	--	---

0 5 V

P

0

5

0 0

0 0

P = Pneumatico
Pneumatic
Pneumatisch
Pneumatiques
Neumático
Pneumatic

0 = Monostabile con ritorno a molla
Monostable spring return
Monostabil mit Federrückstellung
Monostable à rappel par ressort
Monoestable con retorno por muelle
Monoestável com retorno por mola

1 = Bistabile
Bistable
Bistabil
Bistable
Biestable
Biestável

5 = 5/2
7 = 5/3

CC = Centri chiusi
Normally closed
Mittelstellung geschlossen
Centre fermé
Centros cerrados
Centro fechado

OC = Centri aperti
Normally exhausted
Mittelstellung offen
Centre ouvert
Centros abiertos
Centro-aberto negativo

00 = Funzione non contemplata
Function not provided
Funktion steht nicht zur Verfügung
Fonction non disponible
Función no contemplada
Função não contemplada

5/2 Vie - Ways - Wege - Voies - Vias - Vias

MONOSTABILE CON RITORNO A MOLLA

MONOSTABLE SPRING RETURN

MONOSTABIL MIT FEDERRÜCKSTELLUNG

MONOSTABLE À RAPPEL PAR RESSORT

MONOESTABLE CON RETORNO POR MUELLE

MONOESTÁVEL COM RETORNO POR MOLA

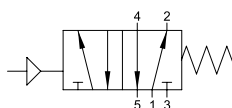

Codice Code Nummer Code Código Código	Vie Ways Wege Voies Vias Vias	Pack.
05V P0 5 00 00	5/2	1

5/2 Vie - Ways - Wege - Voies - Vias - Vias

BISTABILE

TWO STABLE POSITIONS

BISTABIL

BISTABLE

BIESTABLE

BIESTÁVEL

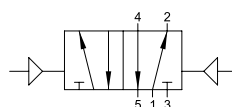

Codice Code Nummer Code Código Código	Vie Ways Wege Voies Vias Vias	Pack.
05V P1 5 00 00	5/2	1

5/3 Vie - Ways - Wege - Voies - Vías - Vias

MONOSTABILE CON RITORNO A MOLLA

MONOSTABLE SPRING RETURN
 MONOSTABIL MIT FEDERRÜCKSTELLUNG
 MONOSTABLE À RAPPEL PAR RESSORT
 MONOESTABLE CON RETORNO POR MUELLE
 MONOESTÁVEL COM RETORNO POR MOLA

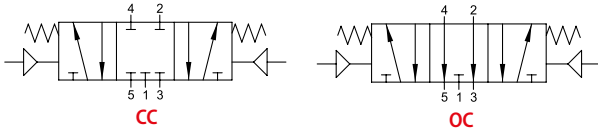

Codice Code Númer Code Código Código	Vie Ways Wege Voies Vías Vias	Funzione Function Funktion Fonction Función Funções	Pack.
05V P0 7 CC 00	5/3	CC	1
05V P0 7 OC 00	5/3	OC	1

05V P0 5 00 00

05V P0 7 CC 00 05V P0 7 OC 00

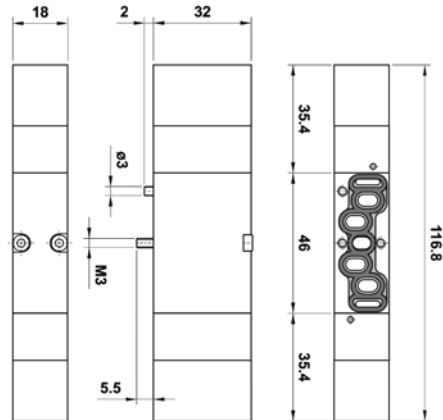
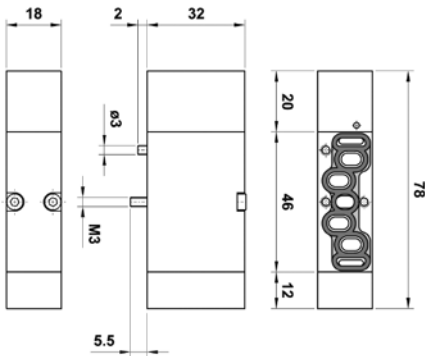

05V P1 5 00 00

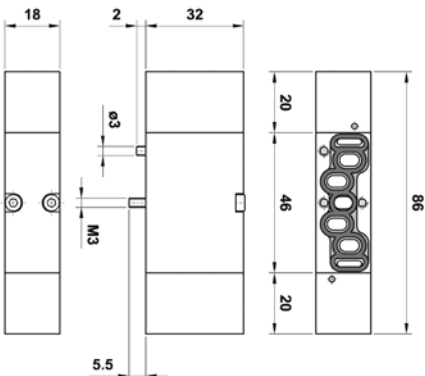

BASI MULTIPLE E ACCESSORI

MULTIPLE BASES AND ACCESSORIES
 MEHRFACH GRUNDPLATTEN UND ZUBEHÖR
 EMBASES MULTIPLES ET ACCESSOIRES
 BASES MÚLTIPLES Y ACCESORIOS
 BASES MÚTIPLAS E ACESSÓRIOS

Tutte le basi e accessori sono complete di viti e guarnizioni per un corretto montaggio.
 All the bases are supplied with screws and seals to secure the correct assembly.
 Alle Grundplatten und Zubehör werden komplett mit Schrauben und Dichtungen für eine ordnungsgemässe Montage geliefert.
 Toutes les embases et les accessoires sont équipés avec des vis et des joints d'étanchéité pour une installation correcte.
 Todos los módulos y accesorios están completos de tornillos y juntas para un correcto montaje.
 Todas as bases e acessórios incluem parafusos e vedações para uma montagem correta.

TERMINALE ANTERIORE CON BASE INTEGRATA

FRONT TERMINAL-BASED INTEGRATED
 FRONT-GRUNDPLATTEN
 EMBASE D'EXTRÉMITÉ (ALIMENTATION)
 TERMINAL ANTERIOR CON BASE INTEGRADA
 TERMINAL FRONTAL COM BASE INTEGRADA



Code	Pack.
05V B1 0 00 00	1

TERMINALE POSTERIORE CON BASE INTEGRATA

REAR TERMINAL-BASED INTEGRATED
 END-GRUNDPLATTEN
 EMBASE D'EXTRÉMITÉ
 TERMINAL POSTERIOR CON BASE INTEGRADA
 TERMINAL TRASEIRO COM BASE INTEGRADA



Code	Pack.
05V B2 0 00 00	1

BASE MODULARE

MODULAR BASE
 ZWISCHEN-GRUNDPLATTEN
 EMBASES INTERMÉDIAIRES
 BASE MODULAR
 BASE MODULAR



Code	Pack.
05V B3 0 00 00	1

ALIMENTAZIONE INTERMEDIA

INTERMEDIATE POWER
 ZWISCHEN-GRUNDPLATTEN FÜR DRUCKEINSPEISUNG
 EMBASES INTERMÉDIAIRES D'ALIMENTATION
 ALIMENTACIÓN INTERMEDIA
 ALIMENTAÇÃO INTERMEDIÁRIA



Code	Pack.
05V B4 0 00 00	1

05V B1 0 00 00

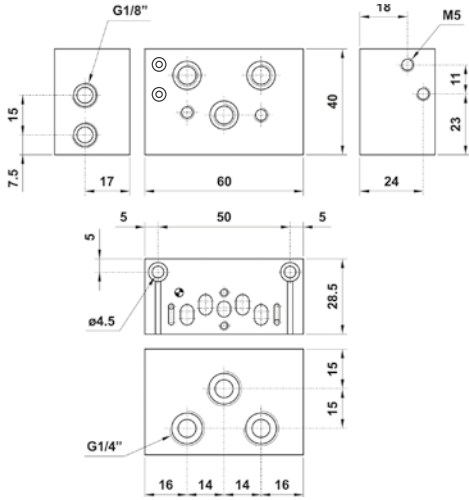

05V B2 0 00 00

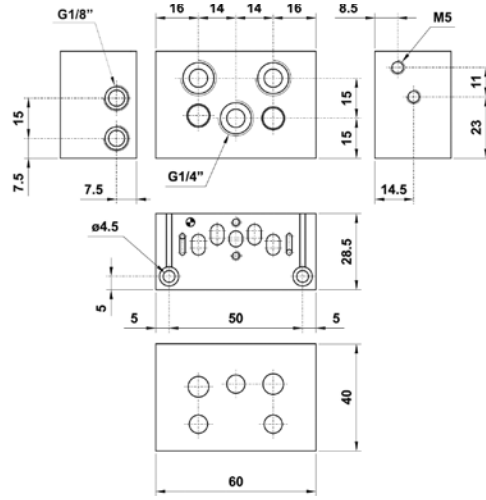

05V B3 0 00 00

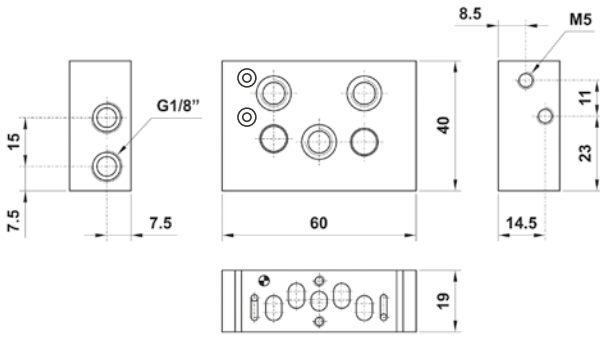

05V B4 0 00 00

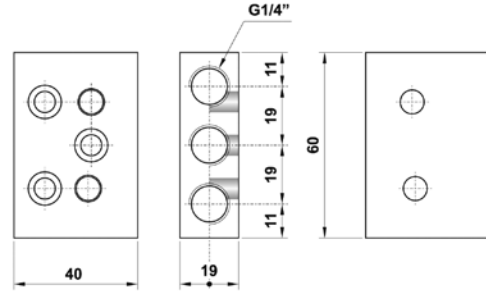

TAPPO INTERMEDIO

INTERMEDIATE PLUG
 VERSCHLUSSPLATTE
 EMBASE DE FERMETURE
 TAPÓN INTERMEDIO
 TAMPÃO INTERMEDIÁRIO



Code	Pack.
05V B8 0 00 00	1

GUARNIZIONE PER TAPPO INTERMEDIO

GASKET FOR INTERMEDIATE PLUG
 DICHTUNG FÜR VERSCHLUSSPLATTE
 JOINT POUR L'EMBASE DE FERMETURE
 JUNTA PARA TAPÓN INTERMEDIO
 VEDAÇÃO PARA TAMPÃO INTERMEDIÁRIO



Code	Pack.
05V B7 0 00 00	1

La guarnizione è fornita con grano da M8.

The gasket is supplied with M8 dowel.

Die Dichtung für Verschlussplatte wird mit Gewindestift M8 geliefert.

Le joint pour l'embase de fermeture est fourni avec vis sans tête M8.

La junta es suministrada con espiga de M8.

A vedação é fornecida com um bujão de M8.

PIASTRINA DI COPERTURA

COVER PLATE
 ABDECKPLATTE
 PLAQUE DE COUVERTURE
 PLACA DE CIERRE
 PLACA CEGA



Code	Pack.
05V B9 0 00 00	1

BASE SINGOLA

INDIVIDUAL BASE
 EINZEL-GRUNDPLATTEN
 EMBASE UNITAIRE
 BASE SIMPLE
 BASE INDIVIDUAL



Code	Pack.
05V B5 0 00 00	1

05V B5 0 00 00

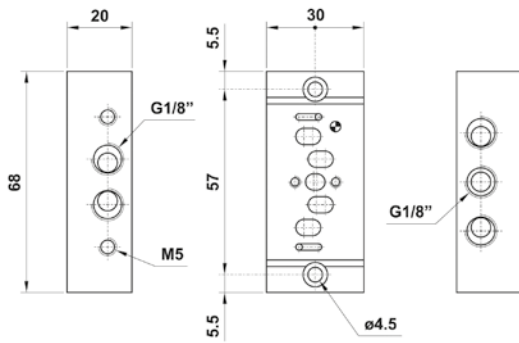

05V B7 0 00 00

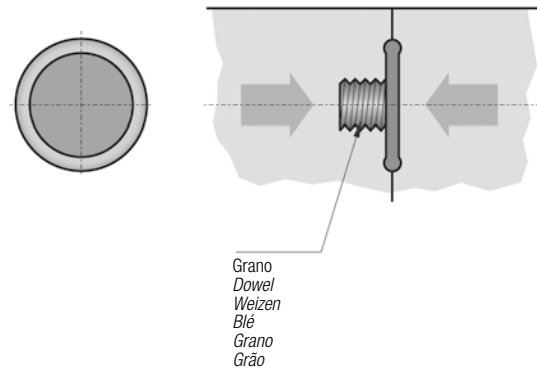

05V B8 0 00 00

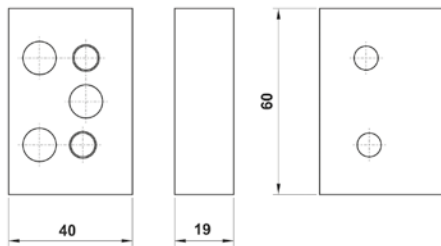

05V B9 0 00 00

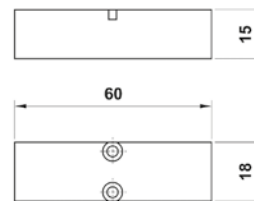

Esempio di montaggio

Example of assembling

Montagebeispiel

Exemple de montage

Ejemplo de montaje

Exemplo de montagem

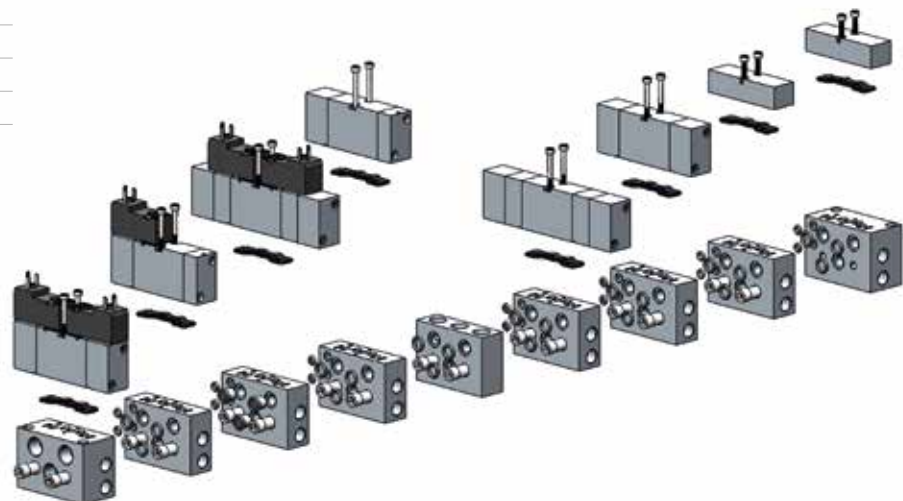



Aignep si riserva il diritto di variare modelli e ingombri senza preavviso.
Aignep reserves the right to vary models and dimensions without notice.
Aignep behält sich das Recht vor, Daten ohne Ankündigung zu ändern.
Aignep se réserve le droit de modifier les données sans préavis.
Aignep reserva-se o direito de alterar os modelos e dimensões sem prévio aviso.

Aggiornamento - Updated - Stand - Mise à jour - Actualización - Atualização: 11/2018



AIGNEP SPA
Via Don G. Bazzoli - 34
25070 Bione (BS)
ITALY

T: +39 0365 896626
F: +39 0365 896561

aignep.it@aignep.com



AIGNEP IBERICA SA
Pol. Ind. el Tortuguer "Can Prat"
Naves 23 y 24 08691
Monistrol de Montserrat - Barcelona
SPAIN

T: +34 93 828 47 36
F: +34 93 828 44 32

aignep.es@aignep.com



**AIGNEP DO BRASIL COMERCIO DE
COMPONENTES PARA AUTOMAÇÃO LTDA**
Rua Campos Mello, 185
Vila Mathias - 11015-011 - Santos/SP
BRASIL

T: +55 13 2138 4049
F: +55 13 2138 4052

aignep.br@aignep.com



AIGNEP USA LLC
7121 Loblolly Pine Blvd
Fairview, TN 37062
U.S.A.

T: +1 615 771 6650
F: +1 615 771 0926

aignep.usa@aignep.com



AIGNEP AG
Industriestrasse 22A
2545 Selzach
SWITZERLAND

T: +41 32 342 09 09
F: +41 32 342 09 11

aignep.ch@aignep.com



AIGNEP FRANCE SARL
2, Avenue des Améthystes
44338 Nantes Cedex 3
FRANCE

T: +33 02 72 24 26 50
F: +33 02 72 24 26 51

aignep.fr@aignep.com



AIGNEP LATAM
Sede:
Calle 15 N 27-78 Local 2
Sec. Paloquemao - 111411
Bogota
COLOMBIA

T: +57 1 37 52 50 1
T: +57 1 37 52 50 8

Sucursal:
Calle 6 SUR 52-80 Local 19
Cc. El Rodeo - 0520024 Medellin
COLOMBIA

T: +57 4 58 70 90 1

aignep.latam@aignep.com



**AIGNEP (Wuxi) FLUID
TECHNOLOGY CO., LT D.**
NO 8, Yanggong Road, Nanhu Main Road
Wuxi, Jiangsu.
CHINA

T: 0510-8544 1923
F: 0510-8540 0223

aignep.cn@aignep.com

www.aignep.com