

GIUNTI AD INNESTO RAPIDO E PISTOLE AD ARIA

AUTOMATIC QUICK COUPLINGS AND BLOW GUNS

SCHNELLVERSCHLUSS-KUPPLUNGEN UND BLASPISTOLEN

COUPLEURS AUTOMATIQUES ET SOUFFLETTES

ENCHUFES RÁPIDOS Y PISTOLAS DE AIRE

CONEXÕES DE ENGATE RÁPIDO E PISTOLAS DE AR



Serie Quick Couplings

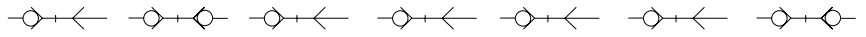

PLUG PROFILE 1:1	STANDARD	SINGLE SHUT OFF	DOUBLE SHUT OFF	STANDARD	MULTI	SAFETY	INOX	DOUBLE SHUT OFF	
	DN 5 MIGNON	210 Pag. 15.11	280 Pag. 15.51	110 Pag. 15.11				180 Pag. 15.51	
	DN 2.5 UNI-ISO 6150-A6	200 Pag. 15.7		100 Pag. 15.7					
	DN 5.5 UNI-ISO 6150-B12 INDUSTRIAL 1/4	220 Pag. 15.17		120 Pag. 15.17	190 Pag. 15.55	620 Pag. 15.87 OB120 Pag. 15.97			
	DN 9 UNI-ISO 6150-B15 INDUSTRIAL 3/8	230 Pag. 15.29		130 Pag. 15.29	720 Pag. 15.71				
	DN 12 UNI-ISO 6150-B17 INDUSTRIAL 1/2	810 Pag. 15.68		710 Pag. 15.68					
	DN 5.5 UNI-ISO 6150-C10	240 Pag. 15.34		140 Pag. 15.34		OB140 Pag. 15.100			
	DN 7.5 - 7.8 EUROPEAN	260 Pag. 15.40	63260 Pag. 15.59	840 Pag. 15.81	160 Pag. 15.40 730 Pag. 15.75	190 Pag. 15.55	660 Pag. 15.91	63190 Pag. 15.59	740 Pag. 15.81
	DN 10 EUROPEAN DN 10	820 Pag. 15.71		720 Pag. 15.71					
	DN 5.5 SWISS	270 Pag. 15.46		170 Pag. 15.46	190 Pag. 15.55	670 Pag. 15.93			
	DN 7.5 JAPANESE	500 Pag. 15.62		400 Pag. 15.62					
	DN 5 ITALIAN	250 Pag. 15.23		120 Pag. 15.23	190 Pag. 15.55	650 Pag. 15.89			
	DN 2.7 MINI	800 Pag. 15.65		700 Pag. 15.65					
	DN 8 FRENCH	510 Pag. 15.106		410 Pag. 15.106					
	DN 12 FRENCH	520 Pag. 15.109		420 Pag. 15.109					
	DN 6 INTERNATIONAL	530 Pag. 15.114		430 Pag. 15.114					
	DN 9 INTERNATIONAL	540 Pag. 15.117		440 Pag. 15.117					
	DN 6 EUROPEAN	560 Pag. 15.122		460 Pag. 15.122					
	DN 9 EUROPEAN	570 Pag. 15.125		470 Pag. 15.125					

WATER / OIL

RECTUS/PARKER 21/90	CAMOZZI 5050 - 5150	CEJN 200		FESTO KD - KS 2	
RECTUS/LEGRIS 23/24 PARKER 20/30 - 1/4 TEMA 1400	HANSEN 3000	CEJN 310	INDUSTRIAL 1/4	GROMELLE 600	US - MIL SPEC C-4109
RECTUS/LEGRIS 30 PARKER 30 - 3/8	HANSEN 4000	CEJN 430	INDUSTRIAL 3/8	GROMELLE 900	US - MIL SPEC C-4109
RECTUS 37	HANSEN 5000	CEJN 550		GROMELLE 1300	US - MIL SPEC C-4109
RECTUS/LEGRIS 18					
RECTUS/LEGRIS 25/26/1600/1625 TEMA 1600	CAMOZZI 5080 - 5180	CEJN 320		FESTO KD - KS 6 KD - KS 4	
RECTUS/LEGRIS 27		CEJN 410			
RECTUS/LEGRIS 14/22 PARKER 50	HANSEN 210	CEJN 300		ARO 210	
RECTUS/LEGRIS 13	SMC KK130	CEJN 315	NITTO KOHKI 200		
RECTUS/LEGRIS PARKER 20/91				FESTO KD - KS 2	
RECTUS 608					
RECTUS 612					
RECTUS 86	DME 1/4				
RECTUS 87	DME 3/8				
RECTUS 10	HASCO Z80/811HT/9 [Øe 9]	CEJN 220 - 221 - 225			
RECTUS 11	HASCO Z80/811HT/13 [Øe 13.5]				

La gamma dei giunti ad innesto rapidi Aignep permette una risposta adeguata ai molteplici bisogni dei nostri clienti. Le differenti applicazioni, le prestazioni e l'affidabilità, sono i vantaggi dati dall'insieme di questa importantissima gamma.

A semplice o doppia intercettazione in ottone nichelato, in acciaio inox, conformi alle principali norme di riferimento possono essere utilizzati per veicolare molteplici fluidi.

A completamento pistole di soffiaggio.

Principali vantaggi

- Passaggi da DN 2,5 a 12 mm
- Profili normalizzati
- Gamme Multipresa
- Montaggio con una sola mano
- Leggerezza ed ingombro ridotto
- Versioni di sicurezza
- Raffreddamento stampi normalizzati
- Silicon Free

Applicazioni

- Impianti Aria Compressa e Strumenti
- Automazione Pneumatica e Fluidica
- Food & Beverage
- Life & Sciences
- Raffreddamento stampi
- Gas inerti, versioni per vuoto

Aignep range of quick couplings is able to satisfy multiple needs of our customers.

Wide variety of models: single & double shut-off, multisocket, safety.

The most popular profiles and nominal diameters available in nickel-plated brass and stainless steel.

For compressed air and for moulding injection cooling system.

To complete the line a wide range of air blow guns.

Main advantages

- DN 2,5 - 12 mm
- Standard profiles
- Multisocket
- Single handed operation
- Light and compact
- Safety version
- Moulding couplers
- Silicon Free

Applications

- Compressed Air & Tools
- Pneumatic & Fluidtechnology
- Food & Beverage
- Life & Sciences
- Cooling System
- Inert Gases, Vacuum

Die Schnellverschlusskupplungs-Serie von Aignep antwortet auf die vielfältigen Bedürfnisse unserer Kunden. Zahlreiche verschiedene Modelle: Einzel- und Doppelabsperrung, Mehrfachstecker, Sicherheitskupplungen.

Die beliebtesten Profile und Nennweiten sind aus vernickeltem Messing und Edelstahl verfügbar.

Für Druckluft und für Spritzguss-Kühlsysteme zu formen. Zur Vervollständigung der Serie eine große Auswahl an Blaspistolen.

Hauptvorteile

- DN 2,5 – 12 mm
- Standard Profile
- Mehrfachstecker
- Einhändige Bedienung
- Leicht und kompakt
- Sicherheits Versionen
- Spritzwerkzeug-Kühlung
- Silikonfrei

Anwendungen

- Druckluft & Werkzeuge
- Pneumatik und Fluidtechnik
- Lebensmittel & Getränke
- Life Science
- Kühlsysteme
- Inertgase, Vakuum

SERIE 190 MULTISOCKET



Un'unica presa per 4 tipi di innesti **IT**

E' un dato di fatto che sul mercato esistono vari profili di innesti ben distinti sia nella forma che nelle dimensioni e generalmente necessitano di essere assemblati con specifiche prese che di norma non sono intercambiabili fra di loro.

Per poter ovviare a questa incompatibilità AIGNEP propone alla sua clientela una soluzione pratica ed economica, un'unica presa da utilizzare con 4 differenti tipi di profili garantendo per tutti una perfetta tenuta.

One socket for 4 different plugs **GB**

It is a matter of fact that on the market are available various types of plugs well distinguished whether on the shape or on the dimensions, usually they need to be assembled with specific sockets which normally are not interchangeable.

To get round to this incompatibility AIGNEP is proud to offer to its customers a practical and cost-effective solution, a unique socket to be used with 4 different types of plugs, ensuring a perfect tightening.

1 Kupplung Für 4 Typen Von Steckern **DE**

Es ist eine Tatsache, dass die auf dem Markt verfügbaren Kupplungen und Stecker mit verschiedenen, nicht kompatiblen Profilen in Form und Grösse geliefert werden, d.h. sie können nicht untereinander ausgetauscht montiert werden.

Um diese Austauschbarkeit zu ermöglichen, bietet AIGNEP seinen Kunden eine praktische und kostengünstige Lösung an, wo mit einer Kupplung 4 verschiedene Profile (Stecker) verwendet werden können und dennoch eine perfekte Abdichtung gewährleistet ist.

1 Corps pour 4 Embouts **FR**

Le marché met à disposition des utilisateurs des différents types de coupleurs qui varient selon les normes, la forme et les dimensions. Souvent il est nécessaire d'assembler plusieurs types de coupleurs qui ne sont pas interchangeables.

Pour contourner cette incompatibilité AIGNEP est fière d'offrir à ses clients une solution pratique, fiable et rentable où un corps unique pour être utilisé avec 4 embouts différents.

Un único enchufe para 4 tipos de adaptador **ES**

Es un dato a remarcar que en el mercado existen varios tipos de adaptadores distintos, ya sea en la forma como en las dimensiones, que generalmente necesitan de enchufes específicos no intercambiables entre ellos.

Para solucionar este problema AIGNEP, propone una solución práctica y económica de intercambiabilidad con todos los adaptadores homologados en el mercado europeo, garantizando para todos una perfecta estanqueidad.

Um único soquete p/ 4 tipos de plugs **PT**

É um fato que no mercado existem vários perfis de plug bem diferentes entre si, seja no seu formato ou com relação às suas medidas e que, por isto normalmente não são intercambiáveis, necessitando de um soquete específico para cada diferente tipo de plug.

Para fugir desta incompatibilidade de tipos de modelos a AIGNEP propõe a seus clientes uma solução prática e econômica: um único soquete para ser utilizado com 4 diferentes tipos de perfis, garantindo para todos uma vedação perfeita.

PROFIL SWISS
SERIE 270

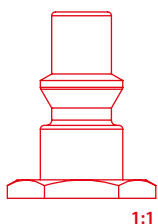

1:1

DN
5.5 mm

Pag. 15.45

PROFIL EUROPEAN
SERIE 260

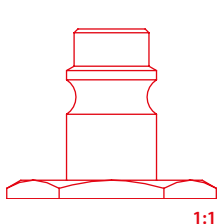

1:1

DN
7.5 - 7.8 mm

Pag. 15.39

PROFIL ITALIAN
SERIE 250

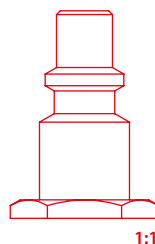

1:1

DN
5 mm

Pag. 15.23

PROFIL UNI ISO 6150 B-12
SERIE 220

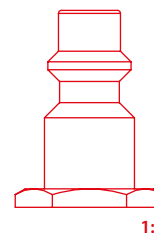

1:1

DN
5.5 mm

Pag. 15.17



CARATTERISTICHE TECNICHE
 TECHNICAL CHARACTERISTICS
 TECHNISCHE ANGABEN
 CARACTÉRISTIQUES TECHNIQUES
 CARACTERÍSTICAS TÉCNICAS
 CARACTERÍSTICAS TÉCNICAS



Norma di Riferimento
 Reference standard
 Entspricht der Norm
 Norme de référence
 Normativa de referencia
 Norma de referència

1907/2006 REACH ✓	2011/65/CE RoHS ✓
PED 2014/68/UE	SILICON FREE

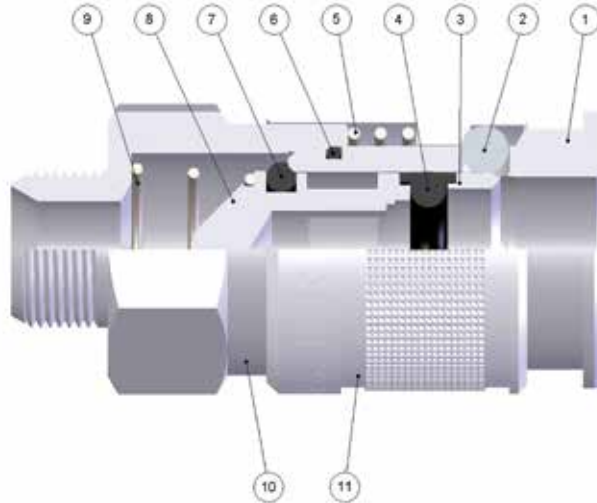

FKM A RICHIESTA
 IF REQUESTED FKM
 FKM AUF ANFRAGE
 FKM SUR DEMANDE
 FKM BAJO DEMANDA
 FKM SOB ENCOMENDA

Materiali e Componenti	IT	Component Parts and Materials	GB	Komponenten und Materialien	DE
1 Corpo in Ottone Nichelato		1 Nickel-Plated Brass Body		1 Körper Messing Vernickelt	
2 Sfera in Acciaio AISI 420		2 Stainless Steel AISI 420 Balls		2 Kugel Edelstahl AISI 420	
3 Anello Guida Innesto in Ottone Nichelato		3 Nickel-Plated Brass Guide Ring Coupling		3 Ring Aus Messing	
4 Guarnizione O-Ring in NBR		4 NBR O-Ring Seals		4 O-Ring NBR	
5 Molla Ghiera in Acciaio AISI 302		5 Stainless Steel AISI 302 Ring Nut Spring		5 Entriegelungsfeder Edelstahl AISI 302	
6 Guarnizione O-Ring in NBR		6 NBR O-Ring Seals		6 O-Ring NBR	
7 Guarnizione O-Ring in NBR		7 NBR O-Ring Seals		7 O-Ring NBR	
8 Otturatore in Ottone Nichelato		8 Nickel-Plated Brass Shutter		8 Verschluss Messing Vernickelt	
9 Molla Otturatore in Acciaio AISI 302		9 Stainless Steel AISI 302 Shutter Spring		9 Verschlussfeder Edelstahl AISI 302	
10 Attacco Terminale in Ottone Nichelato		10 Nickel-Plated Brass Coupling Back Part		10 Einschraubkörper Messing Vernickelt	
11 Ghiera in Ottone Nichelato		11 Nickel-Plated Brass Sleeve		11 Entriegelungshülse Messing Vernickelt	

Matériaux et Composants	FR	Materialies y Componentes	ES	Materialis e Componentes	PT
1 Corps: Laiton Nickelé		1 Cuerpo en latón niquelado		1 Corpo em latão niquelado	
2 Bille: Acier Inoxydable AISI 420		2 Esfera en acero AISI 420		2 Esfera em aço AISI 420	
3 Bague en Laiton		3 Anillo guía enchufe en latón niquelado		3 Anel guia do plug em latão niquelado	
4 Joint Torique en NBR		4 Junta tórica en NBR		4 Vedação O-Ring em NBR	
5 Ressort de Bague: Acier Inoxydable AISI 302		5 Muelle tuerca en acero AISI 302		5 Mola de porca em aço AISI 302	
6 Joint Torique en NBR		6 Junta tórica en NBR		6 Vedação O-Ring em NBR	
7 Joint Torique en NBR		7 Junta tórica en NBR		7 Vedação O-Ring em NBR	
8 Clapet en Laiton Nickelé		8 Obturador en latón niquelado		8 Obturador em latão niquelado	
9 Ressort de Clapet: Acier Inoxydable AISI 302		9 Muelle obturador en acero AISI 302		9 Mola do obturador em aço AISI 302	
10 Corps: Laiton Nickelé		10 Conexión terminal en latón niquelado		10 Conexão terminal em latão niquelado	
11 Bague: Laiton Nickelé		11 Tuerca en latón niquelado		11 Porca em latão niquelado	



Temperature
 Temperatures
 Temperatur
 Températures
 Temperaturas
 Temperaturas

- 20 °C
+ 80 °C

Con O-ring in FKM
 With FKM O-ring
 Mit O-ring in FKM
 Avec Joints en FKM
 Con Junta tórica en FKM
 Com O-ring em FKM

- 10 °C
+ 200 °C



Fluidi compatibili
 Aria compressa

Fluids
 Compressed air

Geeignete Medien
 Druckluft

Fluides compatibles
 Air comprimé

Fluidos compatibles
 Aire comprimido

Fluidos compatíveis
 Ar comprimido

Per altri fluidi, consultare l'ufficio tecnico Aignep.
 For other fluids, consult the technical department Aignep.
 Für andere Flüssigkeiten, kontaktieren Sie uns.
 Pour d'autres fluides, veuillez nous consulter.
 Para otros fluidos póngase en contacto con el departamento técnico Aignep.
 Para outros fluidos consulte o departamento técnico da Aignep.



Pressione d'esercizio

Working Pressures

Betriebsdruck

Pression de service

Presión de Ejercicio

Pressão de Trabalho

0 bar

16 bar



Max pressione statica (no pulsazioni)

Maximum static pressure (no pulsations)

Maximaler statischer Betriebsdruck (ohne pulsations)

Pression statique maximale (sans pulsation)

Presión estática máxima (sin pulsaciones)

Pressão estática máxima (sem pulsações)

35 bar



Portata

NI/min

Flow Rate

Durchflusswerte

Débit

Caudal de Flujo

Vazão

Innesto Plug Stecker Embout Adaptador Plug	6 bar Δ 1	6 bar Δ 0.5	6 bar Δ 0*
220	900	700	1450
250	800	700	1300
260 (7.5)	1350	1000	2150
260 (7.8)	1510	1200	2250
270	1100	750	1600

* Scarico libero - Exhaust Free - Kostenlose Auspuff - Échappement libre - Escape Libre - Descarga livree.



Filettatura

IT

Threads

GB

Gewindearten

DE

Gas cilindrica conforme ISO 228 Classe A.

Parallel gas in conformity with ISO 228 Class A.

Zylindrisches Gewinde nach Norm ISO 228 Classe A.

Filetages

FR

Roscas

ES

Roscas

PT

Filetage cylindrique conforme: ISO 228 Classe A.

Gas cilindrica conforme ISO 228 Clase A.

Gas paralela conforme ISO 228 Classe A.

191

PRESA MASCHIO

MALE SOCKET

VERSCHLUSS-KUPPLUNG MIT AUSSENGEWINDE

COUPLEUR MÂLE

ENCHUFE MACHO

SOQUETE COM ROSCA MACHO

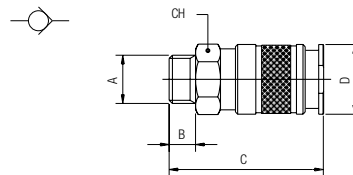

Code	A	B	C	D	CH	Pack.
00191 00 001	1/4	8	49	24	21	10
00191 00 002	3/8	9	50	24	21	10
00191 00 003	1/2	10	51	24	24	10

192

PRESA FEMMINA

FEMALE SOCKET

VERSCHLUSS-KUPPLUNG MIT INNENGEWINDE

COUPLEUR FEMELLE

ENCHUFE HEMBRA

SOQUETE COM ROSCA FÊMEA

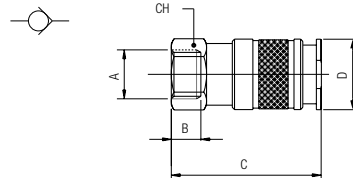

Code	A	B	C	D	CH	Pack.
00192 00 001	1/4	11	51	24	21	10
00192 00 002	3/8	11.5	51	24	21	10
00192 00 003	1/2	14	55	24	24	10

193

PRESA A CALZAMENTO CON MOLLA

COMPRESSION SOCKET WITH SPRING
 VERSCHLUSS-KUPPLUNG MIT KNICKSCHUTZFEDER
 COUPLEUR AVEC RESSORT DE PROTECTION
 ENCHUFE TUBO CON MUELLE
 SOQUETE COM CONEXÃO PUSH-ON COM MOLA

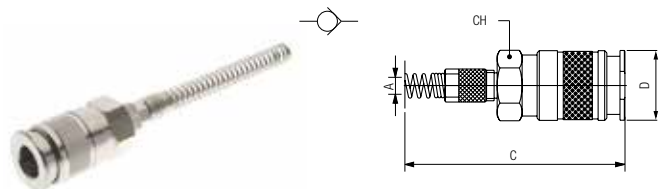

Code	A	B	C	D	CH	Pack.
00193 00 001	6/4	-	138	24	21	10
00193 00 002	8/6	-	144.5	24	21	10
00193 00 004	10/6.5	-	153.5	24	21	10
00193 00 003	10/8	-	153.5	24	21	10
00193 00 005	12/10	-	159	24	21	10

194

PRESA A CALZAMENTO

COMPRESSION SOCKET
 VERSCHLUSS-KUPPLUNG MIT ÜBERWURFVERSCHRAUBUNG
 COUPLEUR RACCORD À COIFFE
 ENCHUFE TUBO
 SOQUETE COM CONEXÃO PUSH-ON

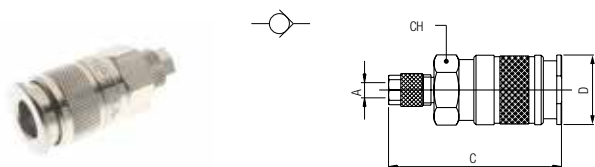

Code	A	B	C	D	CH	Pack.
00194 00 001	6/4	-	55	24	21	10
00194 00 002	8/6	-	55	24	21	10
00194 00 003	10/8	-	55	24	21	10
00194 00 007	12/10	-	57.5	24	21	10

195

PRESA CON PORTAGOMMA A RESCA

SOCKET WITH REST FOR RUBBER HOSE
 VERSCHLUSS-KUPPLUNG MIT SCHLAUCHTÜLLE
 COUPLEUR À DOUILLE ANNELÉE POUR TUBE
 ENCHUFE ESPIGA
 SOQUETE COM ESPIGÃO PARA MANGUEIRA DE BORRACHA

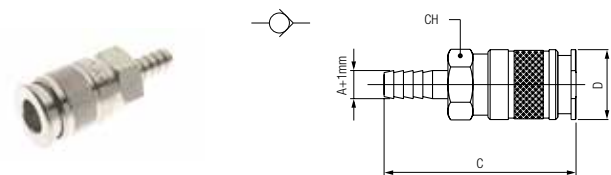

Code	A	B	C	D	CH	Pack.
00195 00 001	6	-	61	24	21	10
00195 00 002	8	-	61	24	21	10
00195 00 003	10	-	61	24	21	10
00195 00 004	12	-	61	24	21	10

196

PRESA CON PORTAGOMMA

SOCKET FOR RUBBER HOSE
 VERSCHLUSS-KUPPLUNG FÜR GUMMISCHLAUCH
 COUPLEUR À DOUILLE ANNELÉE POUR TUBE
 ENCHUFE CON PORTAGOMA
 SOQUETE COM ESPIGÃO PARA TUBO DE BORRACHA

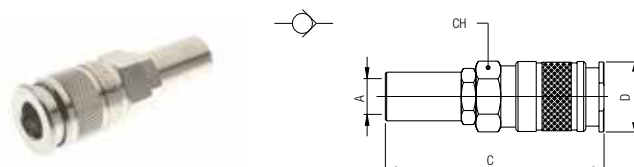

Code	A	B	C	D	CH	Pack.
00196 00 001	14/6	-	71	24	21	10
00196 00 002	17/8	-	71	24	21	10
00196 00 003	19/10	-	71	24	21	10

SERIE 160 EUROPEAN PROFILE

DN
7.5 - 7.8 mm

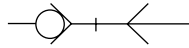

EUROPEAN

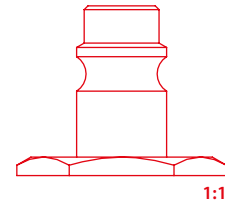

261

INNESTO MASCHIO

MALE PLUG
STECKER MIT AUSSENGEWINDE
EMBOUT MÂLE
ADAPTADOR MACHO
PLUG COM ROSCA MACHO

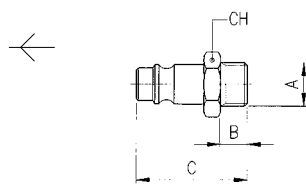

Code	A	B	C	D	CH	Pack.
00261 00 01 03 NB	1/4	8	33	-	17	10
00261 00 01 04 NB	3/8	9	34	-	19	10
00261 00 01 05 NB	1/2	10	35.5	-	24	10

261AC DN 7.8

INNESTO IN ACCIAIO MASCHIO

STEEL MALE PLUG
STECKER MIT AUSSENGEWINDE AUS STAHL
EMBOUT MÂLE EN ACIER
ADAPTADOR EN ACERO MACHO
PLUG EM AÇO COM ROSCA MACHO

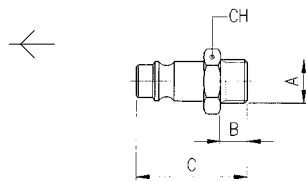

Code	A	B	C	D	CH	Pack.
261AC 00 51 03 ZI	1/4	8	33	-	17	10
261AC 00 51 04 ZI	3/8	9	34	-	19	10
261AC 00 51 05 ZI	1/2	10	35.5	-	24	10

ACCIAIO INDURITO
HARDENED STEEL
GEHÄRTETEM STAHL
ACIER TREMPÉ
ACERO CURTIDO
AÇO ENDURECIDO

262

INNESTO FEMMINA

FEMALE PLUG
STECKER MIT INNENGEWINDE
EMBOUT FEMELLE
ADAPTADOR HEMBRA
PLUG COM ROSCA FÊMEA

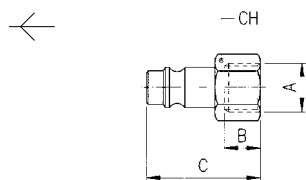

Code	A	B	C	D	CH	Pack.
00262 00 01 03 NB	1/4	11	33	-	17	10
00262 00 01 04 NB	3/8	11.5	33.5	-	19	10
00262 00 01 05 NB	1/2	14	36	-	24	10

262AC DN 7.8

INNESTO IN ACCIAIO FEMMINA

STEEL FEMALE PLUG

STECKER MIT INNENGEWINDE AUS STAHL

EMBOUT FEMELLE EN ACIER

ADAPTADOR EN ACERO HEMBRA

PLUG EM AÇO COM ROSCA FÊMEA

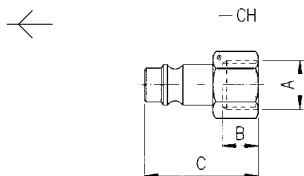

Code	A	B	C	D	CH	Pack.
262AC 00 51 03 ZI	1/4	11	33	-	17	10
262AC 00 51 04 ZI	3/8	11.5	33.5	-	19	10
262AC 00 51 05 ZI	1/2	14	36	-	24	10

ACCIAIO INDURITO
HARDENED STEEL
GEHÄRTETEM STAHL
ACIER TREMPÉ
ACERO CURTIDO
AÇO ENDURECIDO

263

INNESTO A CALZAMENTO CON MOLLA

COMPRESSION PLUG WITH SPRING

STECKER MIT KNICKSCHUTZFEDER

EMBOUT AVEC RESSORT DE PROTECTION

ADAPTADOR TUBO CON MUELLE

PLUG COM CONEXÃO PUSH-ON COM MOLLA

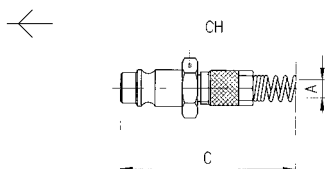

Code	A	B	C	D	CH	Pack.
00263 00 001	6/4	-	124.5	-	13	10
00263 00 002	8/6	-	130	-	13	10
00263 00 003	10/8	-	137.5	-	14	10
00263 00 004	12/10	-	143	-	16	10

264

INNESTO A CALZAMENTO

COMPRESSION PLUG

STECKER MIT ÜBERWURFVERSCHRAUBUNG

EMBOUT À RACCORD À COIFFE

ADAPTADOR TUBO

PLUG COM CONEXÃO PUSH-ON

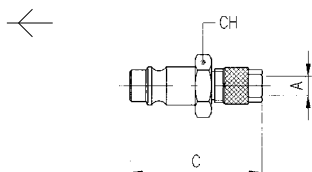

Code	A	B	C	D	CH	Pack.
00264 00 001	6/4	-	36	-	13	10
00264 00 002	8/6	-	36.5	-	13	10
00264 00 003	10/8	-	38.5	-	14	10
00264 00 004	12/10	-	47.5	-	16	10

265

INNESTO CON PORTAGOMMA A RESCA

PLUG WITH REST FOR RUBBER HOSE

STECKER MIT SCHLAUCHTÜLLE

EMBOUT À DOUILLE ANNELÉE POUR TUBE

ADAPTADOR ESPIGA

PLUG COM ESPIGÃO PARA TUBO DE BORRACHA

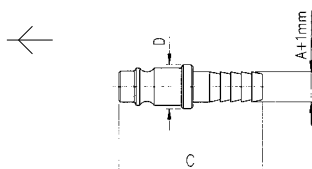

Code	A	B	C	D	CH	Pack.
00265 00 01 X4 NB	6	-	39.5	12	-	10
00265 00 01 X7 NB	8	-	39.5	12	-	10
00265 00 01 X9 NB	10	-	42.5	14	-	10
00265 00 01 Y1 NB	12	-	42.5	16	-	10

265AC DN 7.8

INNESTO IN ACCIAIO CON PORTAGOMMA A RESCA

STEEL PLUG WITH REST FOR RUBBER HOSE

STECKER MIT SCHLAUCHTÜLLE AUS STAHL

EMBOUT À DOUILLE ANNELÉE POUR TUBE EN ACIER

ADAPTADOR EN ACERO ESPIGA

PLUG EM AÇO COM ESPIGÃO PARA TUBO DE BORRACHA

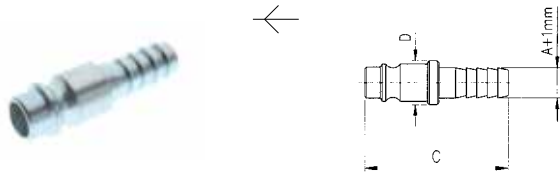

Code	A	B	C	D	CH	Pack.
265AC 00 51 X4 ZI	6	-	39.5	12	-	10
265AC 00 51 X7 ZI	8	-	39.5	12	-	10
265AC 00 51 X9 ZI	10	-	42.5	14	-	10
265AC 00 51 Y1 ZI	12	-	42.5	16	-	10

ACCIAIO INDURITO
HARDENED STEEL
GEHÄRTETEM STAHL
ACIER TREMPÉ
ACERO CURTIDO
AÇO ENDURECIDO

266

INNESTO CON PORTAGOMMA

PLUG FOR RUBBER HOSE

STECKER FÜR GUMMISCHLAUCH

EMBOUT POUR TUBE

ADAPTADOR CON PORTAGOMA

PLUG COM ESPIGÃO PARA TUBO DE BORRACHA

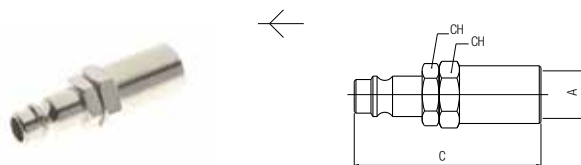

Code	A	B	C	CH1	CH2	Pack.
00266 00 001	14/6	-	55	15	17	10
00266 00 002	17/8	-	55	15	20	10
00266 00 003	19/10	-	55	15	22	10

267

INNESTO A BAIONETTA

BAYONET PLUG

STECKER MIT BAJONETT-VERSCHLUSS

EMBOUT À BAIONNETTE

ADAPTADOR BAYONETA

PLUG COM CONEXÃO TIPO BAIONETA

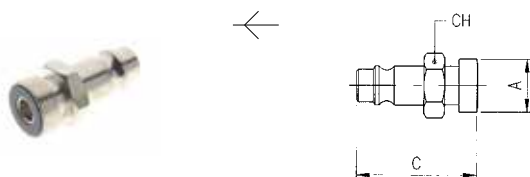

Code	A	B	C	D	CH	Pack.
00267 00 001	15	-	33.5	-	15	10

268

INNESTO A SCARICO PROGRESSIVO

PLUG WITH GRADUAL EXHAUST

STECKER MIT PROGRESSIVER ENTLASTUNG

EMBOUT À PASSAGE PROGRESSIF





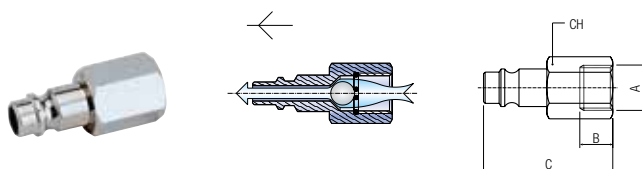











ADAPTADOR DE DESCARGA PROGRESIVA

PLUG COM ESCAPE PROGRESSIVO



Code	A	B	C	CH	Pack.
00268 00 001	1/4	11	41.5	17	10

Prese ad Innesto Rapido - Quick Couplings - Schnellverschluss Kupplungen
Coupleurs Automatiques - Enchufes Rápidos - Conexões de Engate Rápido

<p>SERIE UNI ISO 6150 A-6</p>  <p>Serie 100 Pag. 15.7 - 15.10</p>	<p>SERIE MIGNON</p>  <p>Serie 110 Pag. 15.11 - 15.16</p>	<p>SERIE UNI ISO 6150 B-12</p>  <p>Serie 120 Pag. 15.17 - 15.22</p>	<p>ITALIAN PROFILE</p>  <p>Serie 120 Pag. 15.23 - 15.28</p>	<p>SERIE UNI ISO 6150 B-15</p>  <p>Serie 130 Pag. 15.29 - 15.33</p>
<p>SERIE UNI ISO 6150 C-10</p>  <p>Serie 140 Pag. 15.34 - 15.39</p>	<p>EUROPEAN PROFILE</p>  <p>Serie 160 Pag. 15.40 - 15.45</p>	<p>SWISS PROFILE</p>  <p>Serie 170 Pag. 15.46 - 15.50</p>	<p>MIGNON PROFILE</p>  <p>Serie 180 Pag. 15.51 - 15.54</p>	<p>MULTISOCKET</p>  <p>Serie 190 - 63190 Pag. 15.55 - 15.61</p>
<p>JAPANESE PROFILE</p>  <p>Serie 400 Pag. 15.62 - 15.64</p>	<p>MINI DN 2,7</p>  <p>Serie 700 Pag. 15.65 - 15.67</p>	<p>SERIE UNI ISO 6150 B-17</p>  <p>Serie 710 Pag. 15.68 - 15.70</p>	<p>B-SOCKET EUROPEAN</p>  <p>Serie 720 Pag. 15.71 - 15.74</p>	<p>EUROPEAN PROFILE New</p>  <p>Serie 730 Pag. 15.75 - 15.80</p>
<p>EUROPEAN PROFILE New</p>  <p>Serie 740 Pag. 15.81 - 15.83</p>				

Prese di Sicurezza ad Innesto Rapido - Safety Quick Couplings - Kupplungen Sicherheit - Coupleurs de Sécurité
Enchufes de Seguridad - Conexões de Segurança

<p>SERIE UNI ISO 6150 B-12</p>  <p>Serie 620 Pag. 15.87 - 15.88</p>	<p>ITALIAN PROFILE</p>  <p>Serie 650 Pag. 15.89 - 15.90</p>	<p>EUROPEAN PROFILE</p>  <p>Serie 660 Pag. 15.91 - 15.92</p>	<p>SWISS PROFILE</p>  <p>Serie 670 Pag. 15.93 - 15.94</p>	<p>SERIE UNI ISO 6150 B-12 New</p>  <p>Serie 0B120 Pag. 15.97 - 15.99</p>
<p>SERIE UNI ISO 6150 C-10 New</p>  <p>Serie 0B140 Pag. 15.100 - 15.102</p>				

Giunti ad Innesto Rapido per Raffreddamento Stampi - Quick Couplings for Molding Cooling - Schnellkupplungen für Spritzgussanwendungen
Coupleurs pour Moules D'injection - Enchufes Rápidos para Refrigeración de Moldes - Conexões de Engate Rápido para Resfriamento de Moldes

<p>FRENCH PROFILE DN 8 - DN 12</p>  <p>Series 410-420 - 510 - 520 Pag. 15.104 - 15.110</p>	<p>INTERNATIONAL PROFILE DN 6 - DN 9</p>  <p>Series 430-440 - 530 - 540 Pag. 15.112 - 15.119</p>	<p>EUROPEAN PROFILE DN 6 - DN 9</p>  <p>Series 460-470 - 560 - 570 Pag. 15.120 - 15.127</p>
--	--	---

Pistole di Soffiaggio - Blow Guns - Blaspistolen - Soufflertes - Pistolas Sopladoras - Pistola de Ar

 <p>Series 360 Pag. 15.129 - 15.130</p>	 <p>Series 300 Pag. 15.131 - 15.133</p>	 <p>Spare Parts Pag. 15.134</p>	 <p>Series 340 Pag. 15.135 - 15.136</p>
---	---	---	---

Aignep si riserva il diritto di variare modelli e ingombri senza preavviso - Aignep reserves the right to vary models and dimensions without notice - Aignep behält sich das Recht vor, Daten ohne Ankündigung zu ändern
 Aignep se reserva el derecho de modificar modelos y dimensiones sin previo aviso - Aignep se réserve le droit de modifier les données sans préavis - Aignep reserva-se o direito de alterar os modelos e dimensões sem prévio aviso

SERIE 110 MIGNON



CARATTERISTICHE TECNICHE
 TECHNICAL CHARACTERISTICS
 TECHNISCHE ANGABEN
 CARACTÉRISTIQUES TECHNIQUES
 CARACTERÍSTICAS TÉCNICAS
 CARACTERÍSTICAS TÉCNICAS



Norma di Riferimento
 Reference standard
 Entspricht der Norm
 Norme de référence
 Normativa de referencia
 Norma de referència

1907/2006
REACH ✓

2011/65/CE
RoHS ✓

PED
 2014/68/UE

SILICON
 FREE

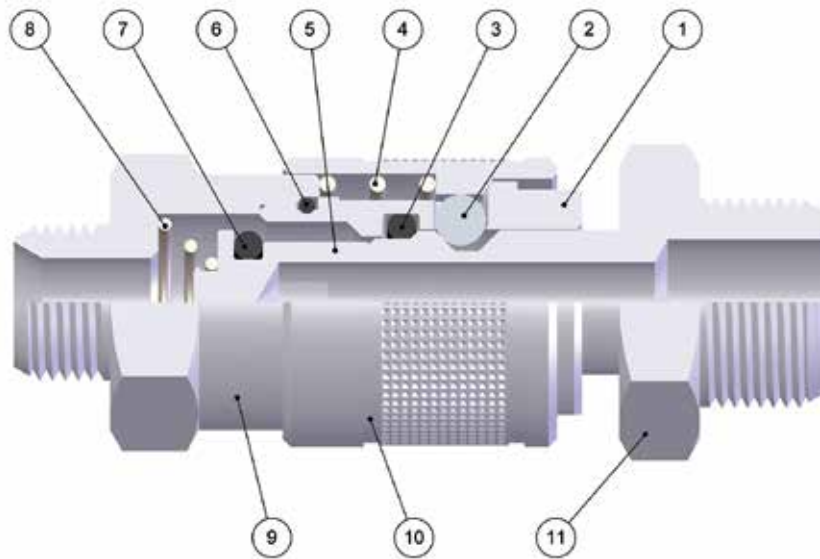

FKM A RICHIESTA
 IF REQUESTED FKM
 FKM AUF ANFRAGE
 FKM SUR DEMANDE
 FKM BAJO DEMANDA
 FKM SOB ENCOMENDA

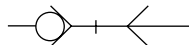

1:1

Materiali e Componenti	IT	Component Parts and Materials	GB	Komponenten und Materialien	DE
1 Corpo in Ottone Nichelato		1 Nickel-Plated Brass Body		1 Körper Messing Vernickelt	
2 Sfera in Acciaio AISI 420		2 Stainless Steel AISI 420 Balls		2 Kugel Edelstahl AISI 420	
3 Guarnizione O-Ring in NBR		3 NBR O-Ring Seals		3 Stecker Führungsring Messing Vernickelt	
4 Molla Ghiera in Acciaio AISI 302		4 Stainless Steel AISI 302 Ring Nut Spring		4 Entriegelungsfeder Edelstahl AISI 302	
5 Otturatore in Ottone Nichelato		5 Nickel-Plated Brass Shutter		5 O-Ring NBR	
6 Guarnizione O-Ring in NBR		6 NBR O-Ring Seals		6 O-Ring NBR	
7 Guarnizione O-Ring in NBR		7 NBR O-Ring Seals		7 Verschluss Messing	
8 Molla Otturatore in Acciaio AISI 302		8 Stainless Steel AISI 302 Shutter Spring		8 Verschlussfeder Edelstahl AISI 302	
9 Attacco Terminale in Ottone Nichelato		9 Nickel-Plated Brass Coupling Back Part		9 Einschraubkörper Messing Vernickelt	
10 Ghiera in Ottone Nichelato		10 Nickel-Plated Brass Sleeve		10 Entriegelungshülse Messing Vernickelt	
11 Innesto in Ottone Nichelato		11 Nickel-Plated Brass Plug Outline		11 Stecker Messing Vernickelt	

Matériaux et Composants	FR	Materiales y Componentes	ES	Materiais e Componentes	PT
1 Corps: Laiton Nickelé		1 Cuerpo en latón niquelado		1 Corpo em Latão Niquelado	
2 Bille: Acier Inoxydable AISI 420		2 Esfera en acero AISI 420		2 Esfera em aço AISI 420	
3 Bague De Guidage: Laiton Nickelé		3 Junta tórica enchufe en NBR		3 Vedação O-Ring em NBR	
4 Ressort De Bague: Acier Inoxydable AISI 302		4 Muelle tuerca en acero AISI 302		4 Mola da porca em aço AISI 302	
5 Joint Torique en NBR		5 Obturador en latón niquelado		5 Obturador em latão niquelado	
6 Joint Torique en NBR		6 Junta tórica en NBR		6 Vedação O-Ring em NBR	
7 Clapet: Laiton		7 Junta tórica en NBR		7 Vedação O-Ring em NBR	
8 Ressort de Clapet: Acier Inoxydable AISI 302		8 Muelle obturador en acero AISI 302		8 Mola do obturador em aço AISI 302	
9 Corps: Laiton Nickelé		9 Terminal de conexión en latón niquelado		9 Conexão terminal em latão niquelado	
10 Bague: Laiton Nickelé		10 Tuerca en latón niquelado		10 Porca em latão niquelado	
11 Embout: Laiton Nickelé		11 Enchufe en latón niquelado		11 Plug em latão niquelado	



Pressione d'esercizio

Working Pressures

Betriebsdruck

Pression de service

Presión de Ejercicio

Pressão de Trabalho

0 bar
12 bar



Max pressione statica (no pulsazioni)

Maximum static pressure (no pulsations)

Maximaler statischer Betriebsdruck (ohne pulsations)

Pression statique maximale (sans pulsation)

Presión estática máxima (sin pulsaciones)

Pressão estática máxima (sem pulsações)

35 bar



Temperature

Temperatures

Temperatur

Températures

Temperaturas

Temperaturas

- 20 °C
+ 80 °C

Con O-ring in FKM

With FKM O-ring

Mit O-ring in FKM

Avec joints en FKM

Con junta tórica en FKM

Com O-ring em FKM

- 10 °C
+ 200 °C



Fluidi compatibili

Aria compressa

Fluids

Compressed air

Geeignete Medien

Druckluft

Fluides compatibles

Air comprimé

Fluidos compatibles

Aire comprimido

Fluidos compatíveis

Ar comprimido

Per altri fluidi, consultare l'ufficio tecnico Aignep.

For other fluids, consult the technical department Aignep.

Für andere Flüssigkeiten, kontaktieren Sie uns.

Pour d'autres fluides, veuillez nous consulter.

Para otros fluidos póngase en contacto con el departamento técnico Aignep.

Para outros fluidos consulte o departamento técnico da Aignep.



Portata

NI/min

Flow Rate

Durchflusswerte

Débit

Caudal de Flujo

Vazão

6 bar Δ 1	6 bar Δ 0.5	6 bar Δ 0*
650	480	1100

* Scarico libero - Exhaust Free - Kostenlose Auspuff - Échappement libre - Escape Libre - Descarga livre.



Filettatura

IT

Gas cilindrica conforme ISO 228 Classe A.

Threads

GB

Parallel gas in conformity with ISO 228 Class A.

Gewindearten

DE

Zylindrisches Gewinde nach Norm ISO 228 Classe A.

Filetages

FR

Filetage cylindrique conforme: ISO 228 Classe A.

Roscas

ES

Gas cilíndrica conforme ISO 228 Clase A.

Roscas

PT

Gas paralela conforme ISO 228 Classe A.

111

PRESA MASCHIO

MALE SOCKET
 VERSCHLUSS-KUPPLUNG MIT AUSSENGEWINDE
 COUPLEUR MÂLE
 ENCHUFE MACHO
 SOQUETE COM ROSCA MACHO

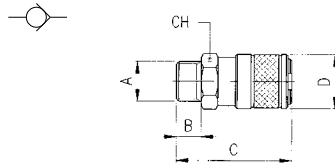

Code	A	B	C	D	CH	Pack.
00111 00 001	1/8	6	35.5	18	16	10
00111 00 002	1/4	8	37.5	18	16	10
00111 00 003	3/8	9	38.5	18	19	10

112

PRESA FEMMINA

FEMALE SOCKET
 VERSCHLUSS-KUPPLUNG MIT INNENGEWINDE
 COUPLEUR FEMELLE
 ENCHUFE HEMBRA
 SOQUETE COM ROSCA FÊMEA

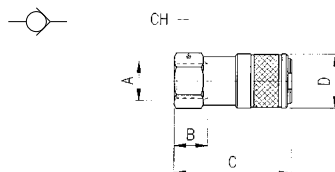

Code	A	B	C	D	CH	Pack.
00112 00 001	1/8	7.5	35	18	16	10
00112 00 002	1/4	11	38.5	18	16	10
00112 00 003	3/8	11.5	39	18	19	10

113

PRESA A CALZAMENTO CON MOLLA

COMPRESSION SOCKET WITH SPRING
 VERSCHLUSS-KUPPLUNG MIT KNICKSCHUTZFEDER
 COUPLEUR RACCORD À COIFFE ET RESSORT DE PROTECTION
 ENCHUFE TUBO CON MUELLE
 SOQUETE COM CONEXÃO PUSH-ON COM MOLA

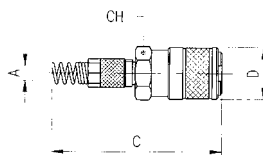

Code	A	B	C	D	CH	Pack.
00113 00 001	6/4	-	124	18	16	10
00113 00 002	8/6	-	129.5	18	16	10

114

PRESA A CALZAMENTO

COMPRESSION SOCKET
 VERSCHLUSS-KUPPLUNG MIT ÜBERWURFVERSCHRAUBUNG
 COUPLEUR RACCORD À COIFFE
 ENCHUFE TUBO
 SOQUETE COM CONEXÃO PUSH-ON

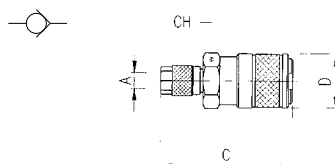

Code	A	B	C	D	CH	Pack.
00114 00 001	6/4	-	42	18	16	10
00114 00 002	8/6	-	42	18	16	10

115

PRESA CON PORTAGOMMA A RESCA

SOCKET WITH REST FOR RUBBER HOSE

VERSCHLUSS-KUPPLUNG MIT SCHLAUCHTÜLLE

COUPLEUR À DOUILLE ANNELÉE POUR TUBE

ENCHUFE ESPIGA

SOQUETE COM ESPIGÃO PARA MANGUEIRA DE BORRACHA

Code	A	B	C	D	CH	Pack.
00115 00 001	4	-	48	18	16	10
00115 00 002	6	-	48	18	16	10
00115 00 003	8	-	48	18	16	10

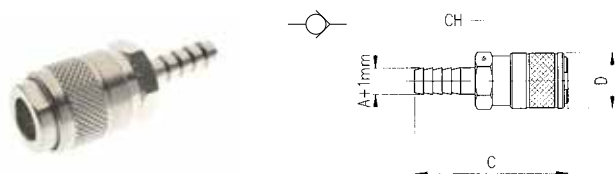

116

PRESA PASSAPARETE MASCHIO

BULKHEAD SOCKET WITH MALE THREADED CONNECTION

VERSCHLUSS-KUPPLUNG SCHOTTVERSION MIT AUSSENGEWINDE

COUPLEUR MÂLE À TRAVERSÉE DE CLOISON

ENCHUFE PASATABIQUES MACHO

SOQUETE PASSA-MURO COM ROSCA MACHO

Code	A	B max	C	D	CH1	CH2	Pack.
00116 00 001	1/8	6	47.5	18	14	16	10
00116 00 002	1/4	8	49.5	18	17	16	10
00116 00 003	3/8	9	51.5	18	20	19	10

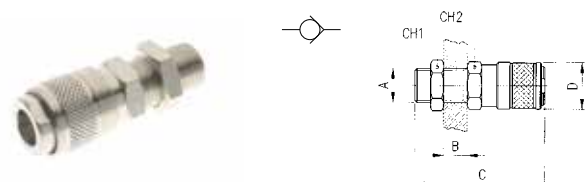

117

PRESA PASSAPARETE A CALZAMENTO CON MOLLA

BULKHEAD SOCKET WITH COMPRESSION CONNECTION WITH SPRING

VERSCHLUSS-KUPPLUNG SCHOTTVERSION MIT KNICKSCHUTZFEDER

COUPLEUR AVEC RESSORT DE PROTECTION, TRAVERSÉE DE CLOISON

ENCHUFE PASATABIQUES TUBO CON MUELLE

SOQUETE PASSA-MURO COM CONEXÃO PUSH-ON COM MOLA

Code	A	B max	C	D	F	CH1	CH2	Pack.
00117 00 001	6/4	8	55.5	18	M10x1	14	16	10
00117 00 002	8/6	8	55.5	18	M12x1	17	16	10

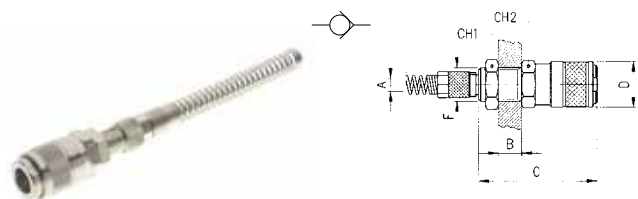

118

PRESA PASSAPARETE A CALZAMENTO

BULKHEAD SOCKET WITH COMPRESSION CONNECTION

VERSCHLUSS-KUPPLUNG SCHOTTVERSION MIT ÜBERWURFVERSCHRAUBUNG

COUPLEUR RACCORD À COIFFE, TRAVERSÉE DE CLOISON

ENCHUFE PASATABIQUES TUBO

SOQUETE PASSA-MURO COM CONEXÃO PUSH-ON

Code	A	B max	C	D	F	CH1	CH2	Pack.
00118 00 001	6/4	8	55.5	18	M10x1	14	16	10
00118 00 002	8/6	8	55.5	18	M12x1	17	16	10

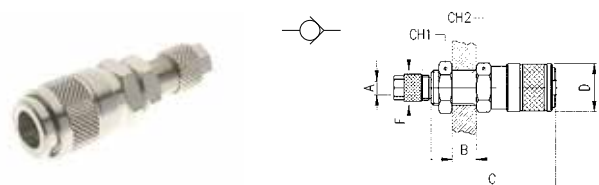

119

PRESA PASSAPARETE CON PORTAGOMMA A RESCA

BULKHEAD SOCKET WITH SPIGOT FOR RUBBER HOSE
 VERSCHLUSS-KUPPLUNG SCHOTTVERSION MIT SCHLAUCHTÜLLE
 COUPLEUR À DOUILLE ANNELÉE POUR TUBE
 ENCHUFE PASATABIQUES ESPIGA
 SOQUETE PASSA-MURO COM ESPIGÃO PARA MANGUEIRA DE BORRACHA

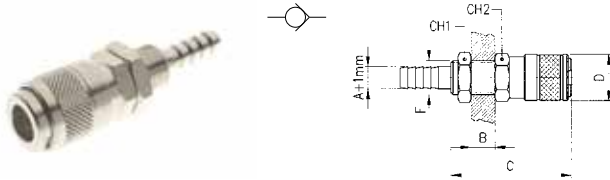

Code	A	B _{max}	C	D	F	CH1	CH2	Pack.
00119 00 001	4	8	61	18	M10x1	14	16	10
00119 00 002	6	8	61	18	M12x1	17	16	10
00119 00 003	8	8	62	18	M14x1	17	16	10

111SW

PRESA SENZA OTTURATORE MASCHIO

MALE SOCKET WITHOUT SHUTTER
 KUPPLUNG OHNE VERSCHLUSS MIT AUSSENGEWINDE
 COUPLEUR MÂLE SANS CLAPET
 ENCHUFE SIN OBTURADOR MACHO
 SOQUETE SEM OBTURADOR COM ROSCA MACHO

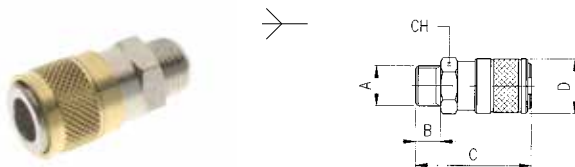

Code	A	B	C	D	CH	Pack.
00111 SW 001	1/8	6	35.5	18	16	10
00111 SW 002	1/4	8	37.5	18	16	10

112SW

PRESA SENZA OTTURATORE FEMMINA

FEMALE SOCKET WITHOUT SHUTTER
 KUPPLUNG OHNE VERSCHLUSS MIT INNENGEWINDE
 COUPLEUR FEMELLE SANS CLAPET
 ENCHUFE SIN OBTURADOR HEMBRA
 SOQUETE SEM OBTURADOR COM ROSCA FÊMEA

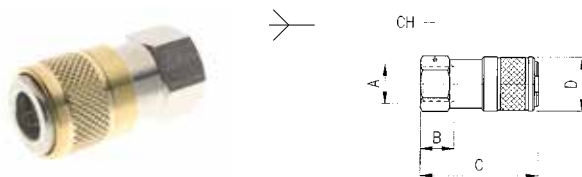

Code	A	B	C	D	CH	Pack.
00112 SW 001	1/8	7.5	35	18	16	10
00112 SW 002	1/4	11	38.5	18	16	10

211

INNESTO MASCHIO

MALE PLUG
 STECKER MIT AUSSENGEWINDE
 EMBOUT MÂLE
 ADAPTADOR MACHO
 PLUG COM ROSCA MACHO



Code	A	B	C	D	CH	Pack.
00211 00 01 02 NB	1/8	6	26	-	14	10
00211 00 01 03 NB	1/4	8	28.5	-	17	10
00211 00 01 04 NB	3/8	9	29.5	-	19	10

212

INNESTO FEMMINA

FEMALE PLUG
 STECKER MIT INNENGEWINDE
 EMBOUT FEMELLE
 ADAPTADOR HEMBRA
 PLUG COM ROSCA FÊMEA

Code	A	B	C	D	CH	Pack.
00212 00 01 02 NB	1/8	7.5	25	-	14	10
00212 00 01 03 NB	1/4	11	28.5	-	17	10
00212 00 01 04 NB	3/8	11.5	29	-	19	10

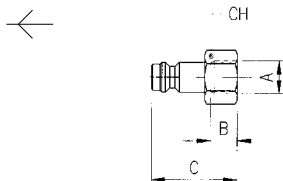

213

INNESTO A CALZAMENTO CON MOLLA

COMPRESSION PLUG WITH SPRING
 STECKER MIT KNICKSCHUTZFEDER
 EMBOUT AVEC RESSORT DE PROTECTION
 ADAPTADOR TUBO CON MUELLE
 PLUG COM CONEXÃO PUSH-ON COM MOLA

Code	A	B	C	D	CH	Pack.
00213 00 001	6/4	-	115	-	12	10
00213 00 002	8/6	-	118.5	-	12	10

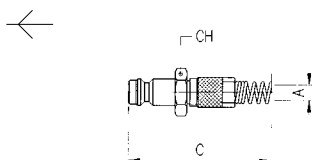

214

INNESTO A CALZAMENTO

COMPRESSION PLUG
 STECKER MIT ÜBERWURFVERSCHRÄUBUNG
 EMBOUT À RACCORD À COIFFE
 ADAPTADOR TUBO
 PLUG COM CONEXÃO PUSH-ON

Code	A	B	C	D	CH	Pack.
00214 00 001	6/4	-	33	-	12	10
00214 00 002	8/6	-	33	-	12	10

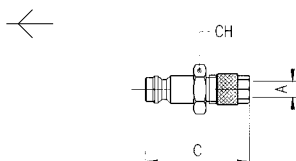

215

INNESTO CON PORTAGOMMA A RESCA

PLUG WITH REST FOR RUBBER HOSE
 STECKER MIT SCHLAUCHTÜLLE
 EMBOUT À DOUILLE ANNELÉE POUR TUBE
 ADAPTADOR ESPIGA
 PLUG COM ESPIGÃO PARA MANGUEIRA DE BORRACHA

Code	A	B	C	D	CH	Pack.
00215 00 01 X1 NB	4	-	35	9	-	10
00215 00 01 X4 NB	6	-	35	9	-	10
00215 00 01 X7 NB	8	-	38	12	-	10

